

- ### Construction Notes:
- All proposed sewer cleanouts that are to be placed within a concrete sidewalk shall be set at the same grade as the sidewalk and utilize a flush mount, brass cap, so that there are no tripping hazards.
 - All fill subgrade and base material shall be compacted to 98% STD in areas to be paved and 95% STD in all other areas.
 - All items to be removed during clearing and grubbing. Remove not only the above ground elements, but all underground elements as well. All excavated material shall become the property of the contractor unless otherwise directed by the Owner. All debris must be disposed of off site.
 - Prior to grading operations, contractor is to strip the first 6" of soil. Contractor shall proof roll the entire site and remove any unstable materials according to TxDOT Specifications. Select fill is to be used in replacing objectionable material.
 - Assure positive drainage across project site to the storm water structures.
 - The proposed limestone gravel pavement area shall follow the same detail and specifications as the asphalt parking lot, omitting the prime coat and asphalt-cement wearing surface. Limestone gravel surface shall be rolled smooth to finish grade.
 - Each utility contractor is responsible for positioning and trenching of service lines. Mark all lines with utility tape. Utility contractors are responsible for coordinating with paving contractor in placement and installation of any necessary utility conduit prior to subgrade preparation. Lines requiring slope control are to be installed first. All other lines of requiring slope control or elevation shall be installed deepest first. Each contractor is responsible for knowing final determination of installation order.
 - Materials and methods for pavement markings shall conform to TxDOT Standard Specifications for Construction of Highways, Streets, and Bridges (current edition), with the following exceptions: 1) Type II marking materials need not be purchased from the Department, and 2) Glass beads may be omitted, but marking material shall be Type II paint-type material.
 - Fire Sprinkler System - potable water supply must be protected by testable double check valve assembly, and install as per City Ordinance.
 - Potable Water Protection - All devices, appurtenances, appliances, and apparatus intended to serve some special function and that connects to the water supply system, shall be provided with protection against backflow and contamination of the water supply system.
 - The Contractor shall be responsible for the containment and proper disposal of all liquid and solid waste associated with this project. The Contractor shall use all means necessary to prevent the occurrence of windblown litter from the project site.
 - Demolition/Construction Waste - Site is required to provide containment for waste prior to and during demolition/construction. Solid waste roll off boxes and/or metal dumpsters shall be supplied by City to permitted contractor(s) only.
 - Where electric facilities are installed, BTU has the right to install, operate, relocate, construct, reconstruct, add to, maintain, inspect, patrol, enlarge, repair, remove, and replace said facilities upon, over, under, and across the property included in the PUE, and the right of ingress and egress on the property adjacent to the PUE to access electric facilities.

- ### Site Specific Notes:
- Current owner of Block 1, Lot 9 of Carrabba Industrial Park, Phase 11, is GRT Interests, Inc., PO Box 663, Bryan, Texas 77806, (979) 778-8850, Grant Carrabba - Vice President.
 - The proposed single story building is Type IIb 8,400 SF without sprinklers, FF=352.40'.
 - Proposed use and improvements: wholesale/fabrication facility including assorted parking, utilities, & landscaping. Facility will not be used for woodworking or the storage/manufacture of upholstered furniture.
 - This lot is not within the 100-YR floodplain according to the DFIRM for Brazos County, Texas and Incorporated Areas, Map No. 48041C0205P, effective April 2, 2014.
 - Current Zoning of the property is Agricultural Open District (A-0).
 - Total lot acreage is 1.44 Acres.
 - All minimum building setbacks shall be in accordance with the City of Bryan Code of Ordinances.
 - Developer/Tenant to submit electrical load information when requesting electrical service from BTU. Contact Line Design @ 621-5770.
 - Access gates shall be manually operated and secured with a chain and pad lock.
 - There are no paint spraying operations anticipated for this development.

- ### Paving Notes:
- The subgrade beneath the concrete sidewalks shall be compacted and "proof-rolled". Any weak or soft areas identified by the "proof-rolling" shall be removed and replaced.
 - A sand leveling course under concrete pavement is NOT permitted.
 - Joint sealant material to be Sonneborn SL-1 or approved equal.
 - Curing compound shall be applied uniformly to the concrete after the surface finishing is complete at the rate recommended by the manufacturer. The curing compound shall meet the requirements of TxDOT Item 526.
 - All concrete for pavement construction shall be to the minimum depth shown on the plans and shall have a minimum 28-day compressive strength of 4000 PSI. The maximum percentage of fly ash replacement of portland cement shall be 20 percent by weight.
 - Contractor shall provide engineer with a proposed pavement expansion and contraction joint plan prior to pavement construction.

Subgrade Stabilization Table:

PI = Plasticity Index	LL = Liquid Limit	
If PI >20 and LL <35, Then Lime Stabilize Subgrade		
If PI >15 and LL >36, Then Lime Stabilize Subgrade		
If PI <5, Then Cement Stabilize Subgrade		
PI	% Required	Material
<5	5%	Cement
<25	5%	Lime
26-33	6%	Lime
34-40	7%	Lime
>40	Determined by ASTM C977 Lime	

Acceptable soils other than those defined by the limits above, do not require stabilization.

- ### Fire Lane Striping:
- All curbs and curb ends shall be painted red with 4" white lettering stating "FIRE LANE-NO PARKING-TOW AWAY ZONE". The phrases should be spaced 15' apart continuously. Fire Lane linework shown on this Site Plan is used to delineate the location of the fire lane for permitting purposes and is not intended to show required painted Fire Lane Striping.
- FIRE LANE ■ NO PARKING ■ TOW AWAY ZONE ■
- Note: Fire lane shall not be painted on Flat work/surface with use of Fire Lane Signage.

- ### Parking Analysis:
- Proposed Improvements:
- 8,400 SF Building
 - 18,000 SF Limestone Gravel Yard
- New Required Parking:
- 9... 1 Space per 1000 SF Building
 - 9... 1 Space per 2000 SF Yard
- 18... Total Required
- New Provided Parking:
- 9... Straight in Parking
 - 2... ADA Parking
 - 7... Bay Parking
- 18... Total Provided

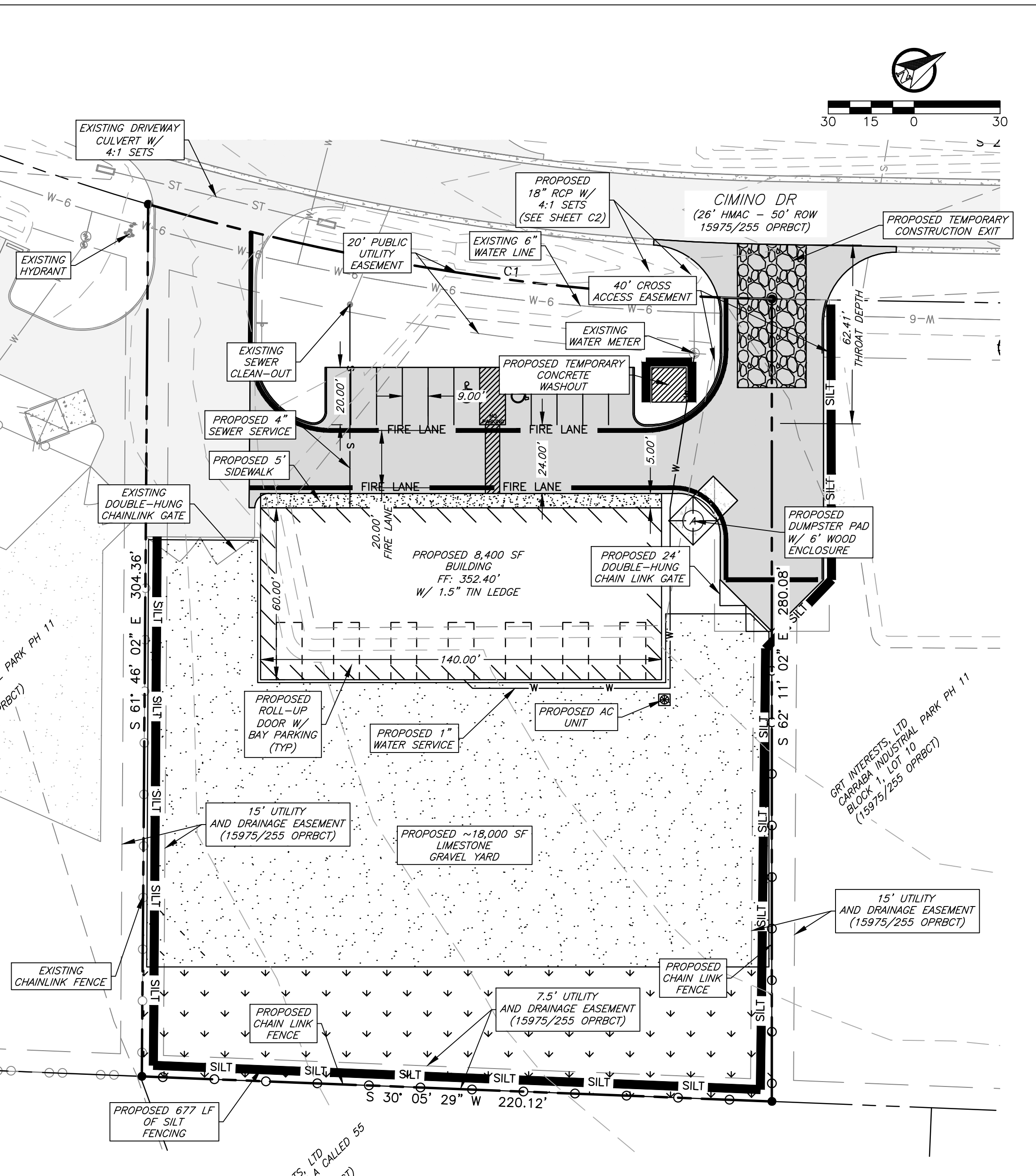
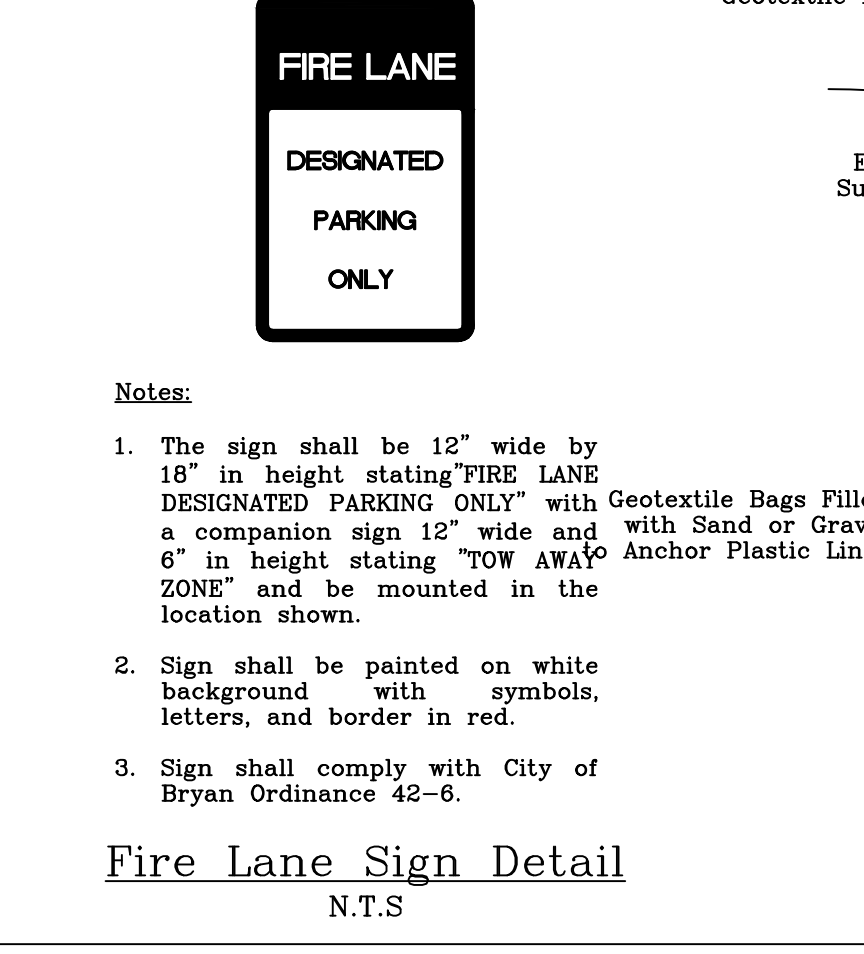
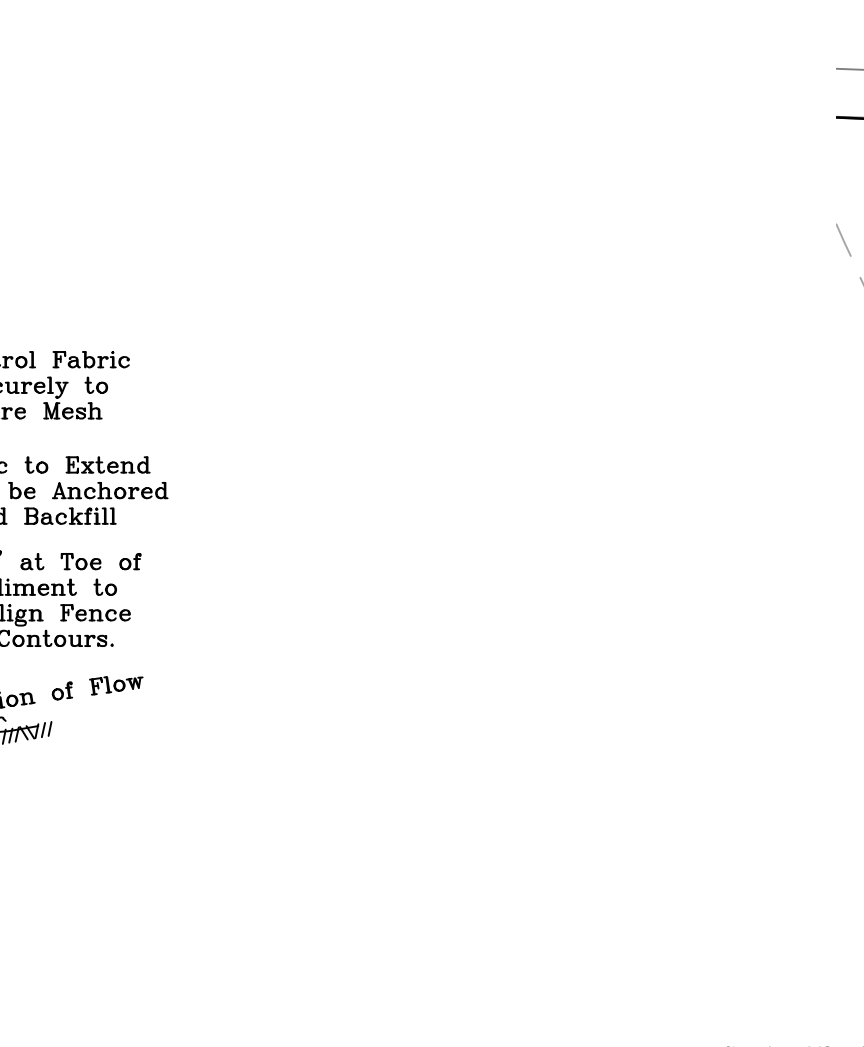
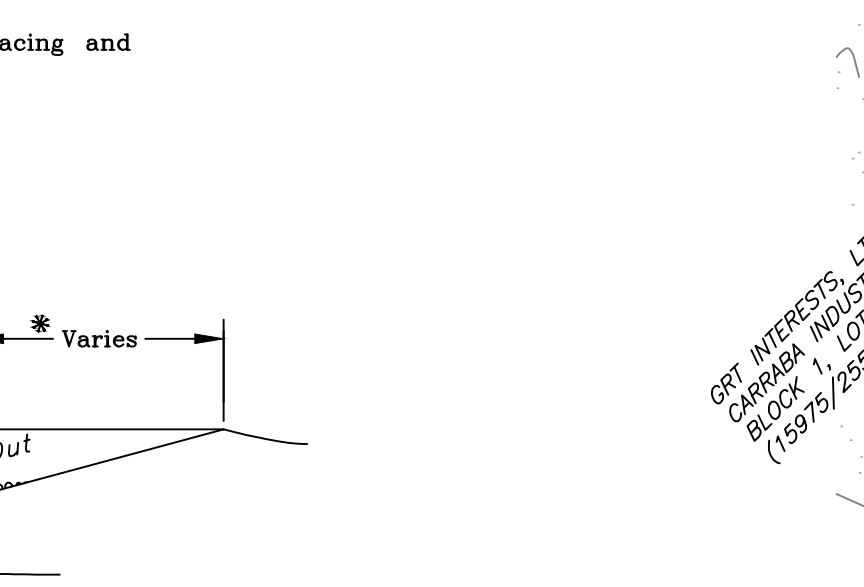
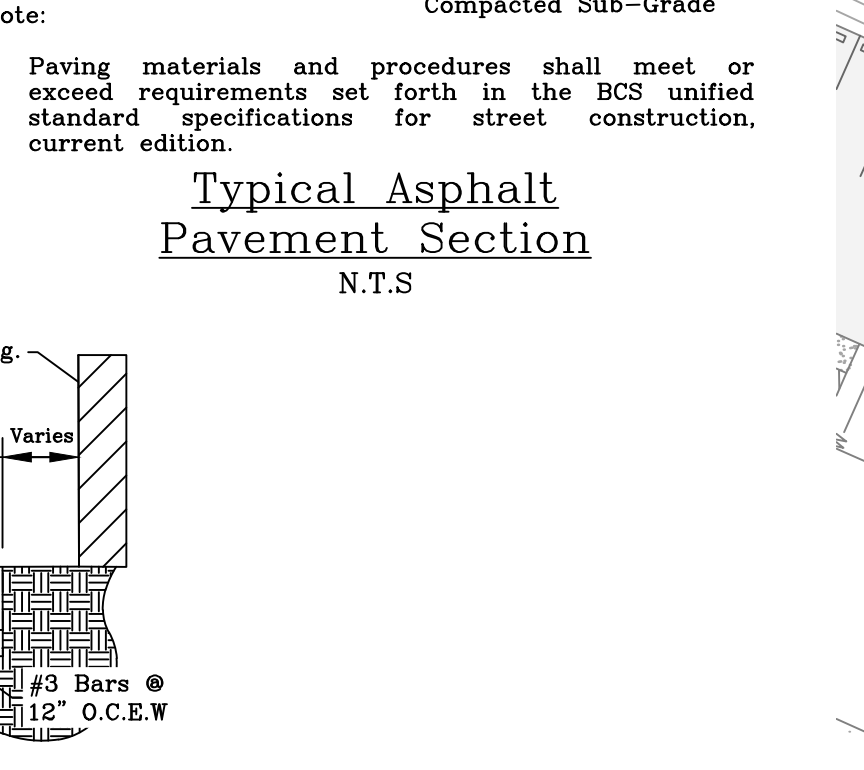
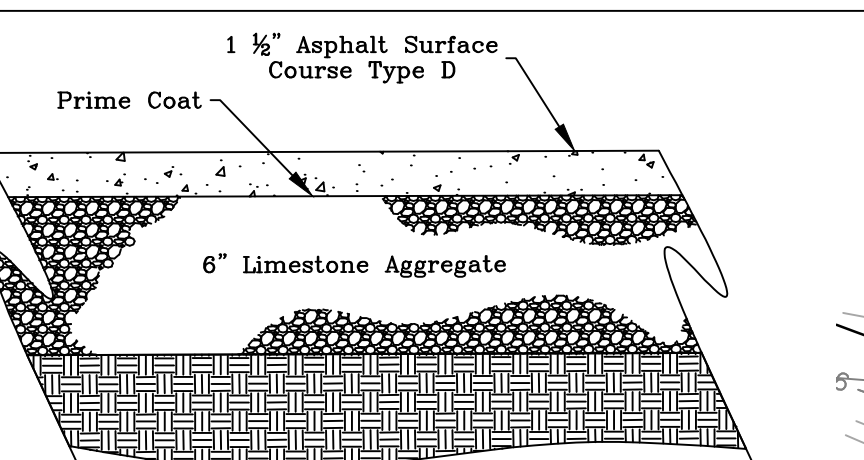
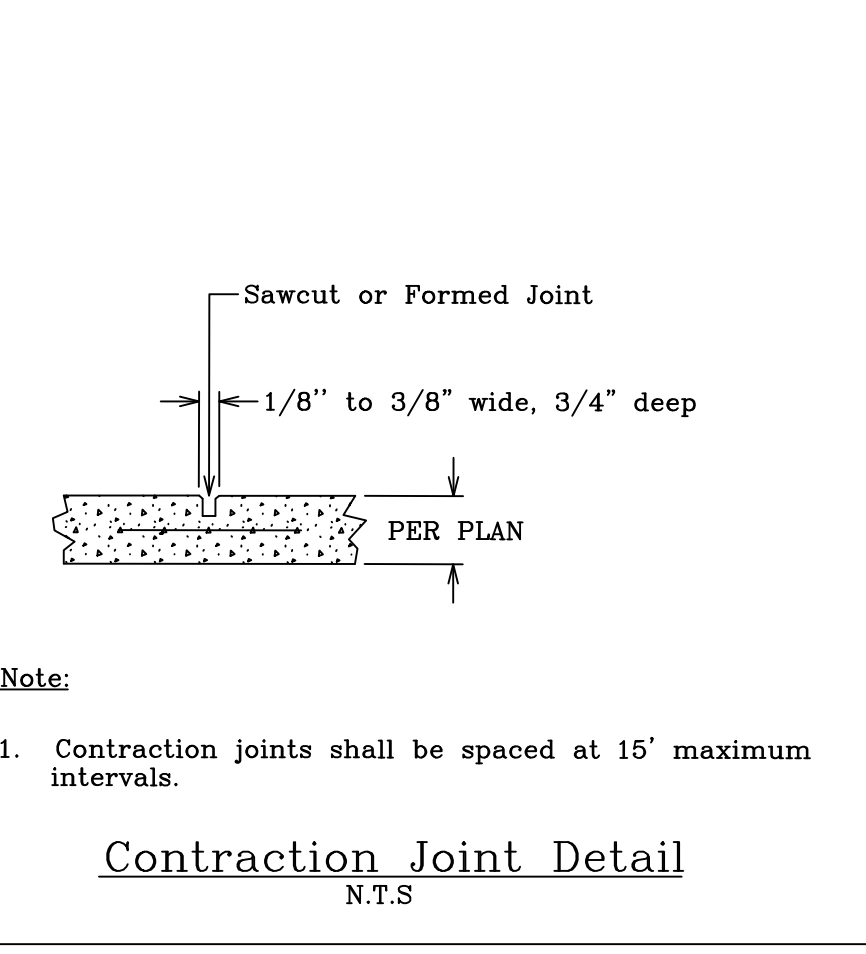
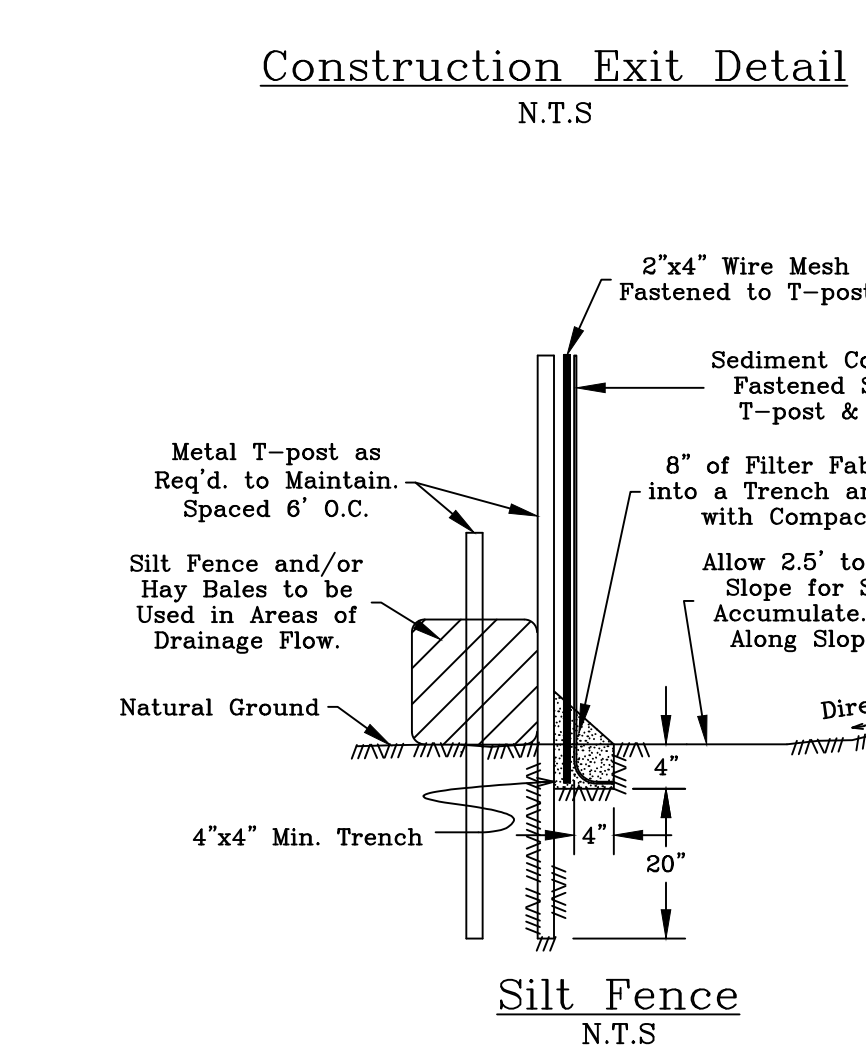
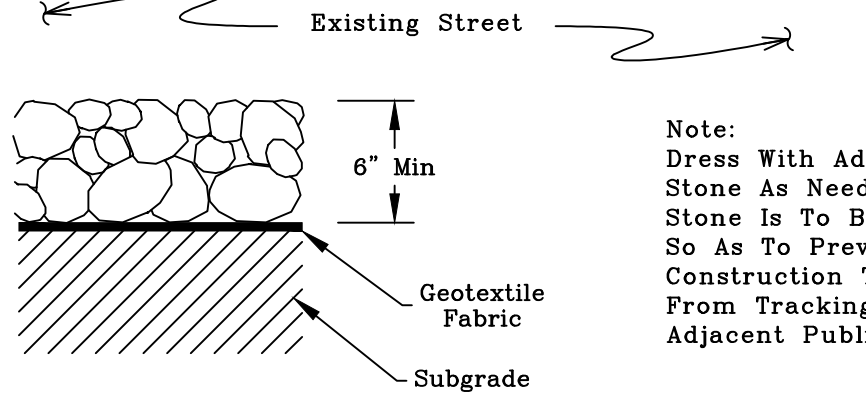
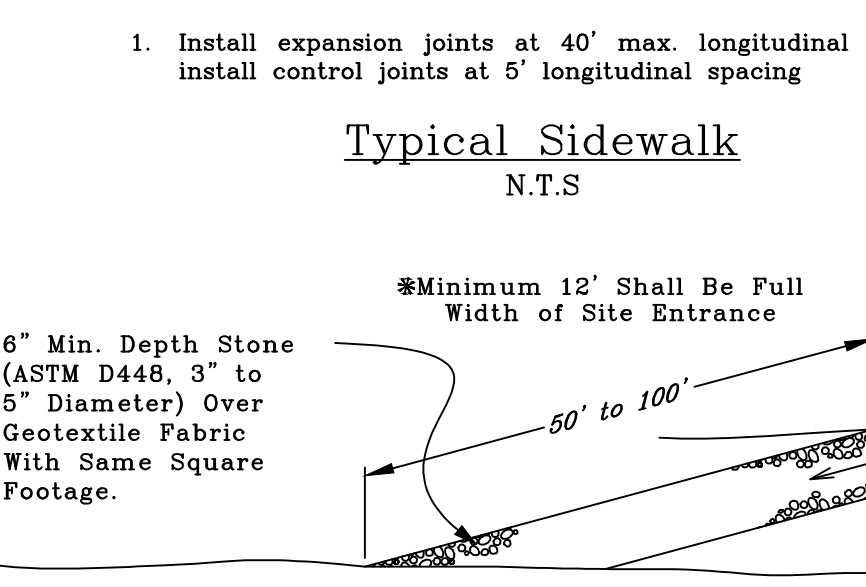
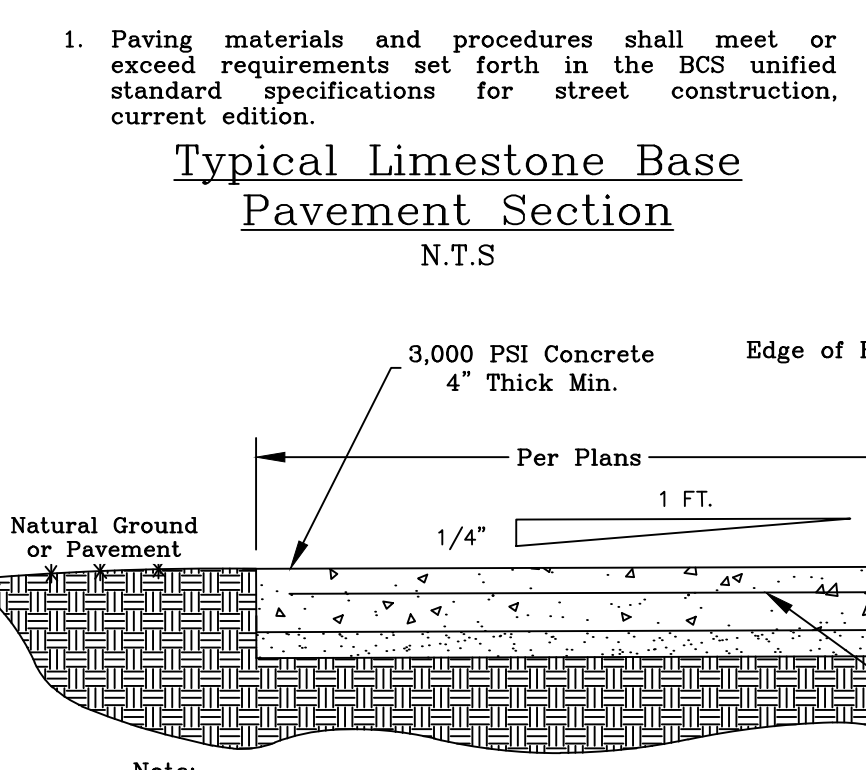
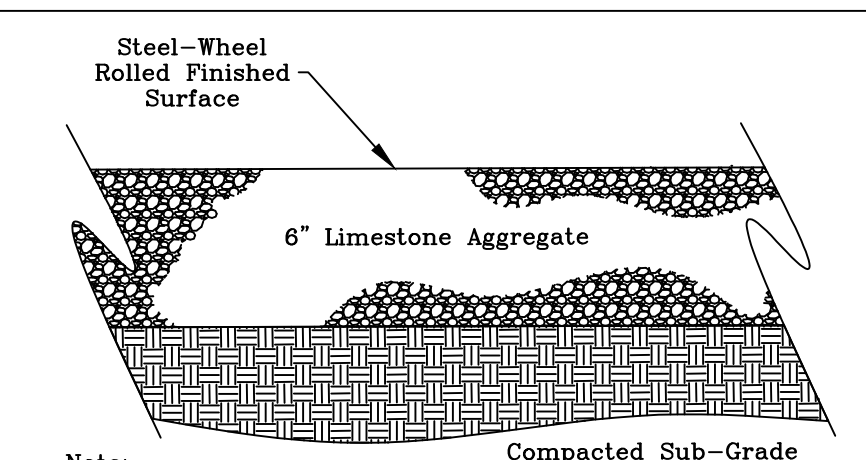
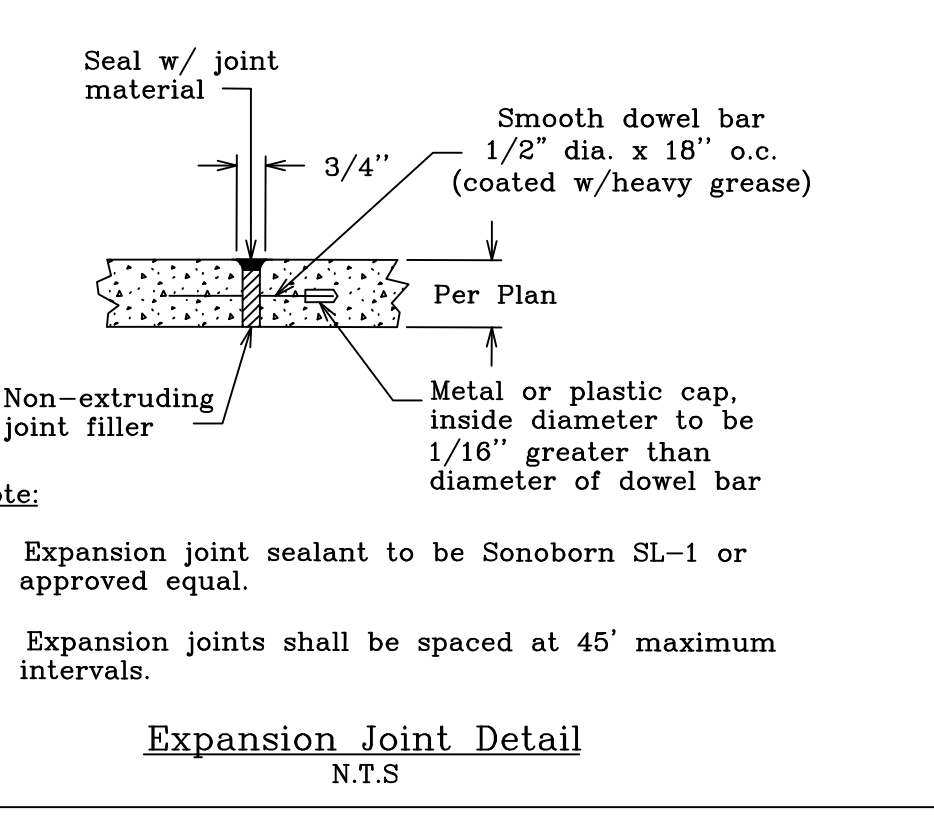
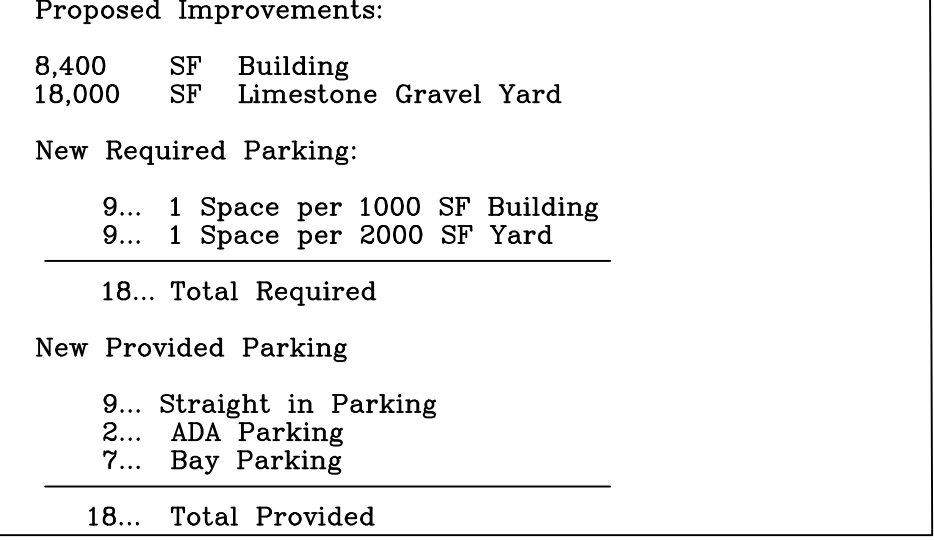

CURVE TABLE

CURVE #	LENGTH	RADIUS	DELTA	CHORD DIRECTION	CHORD LENGTH	TANGENT
C1	220.87'	830.00'	15° 14' 49"	N 36° 26' 12" E	220.22'	111.09'

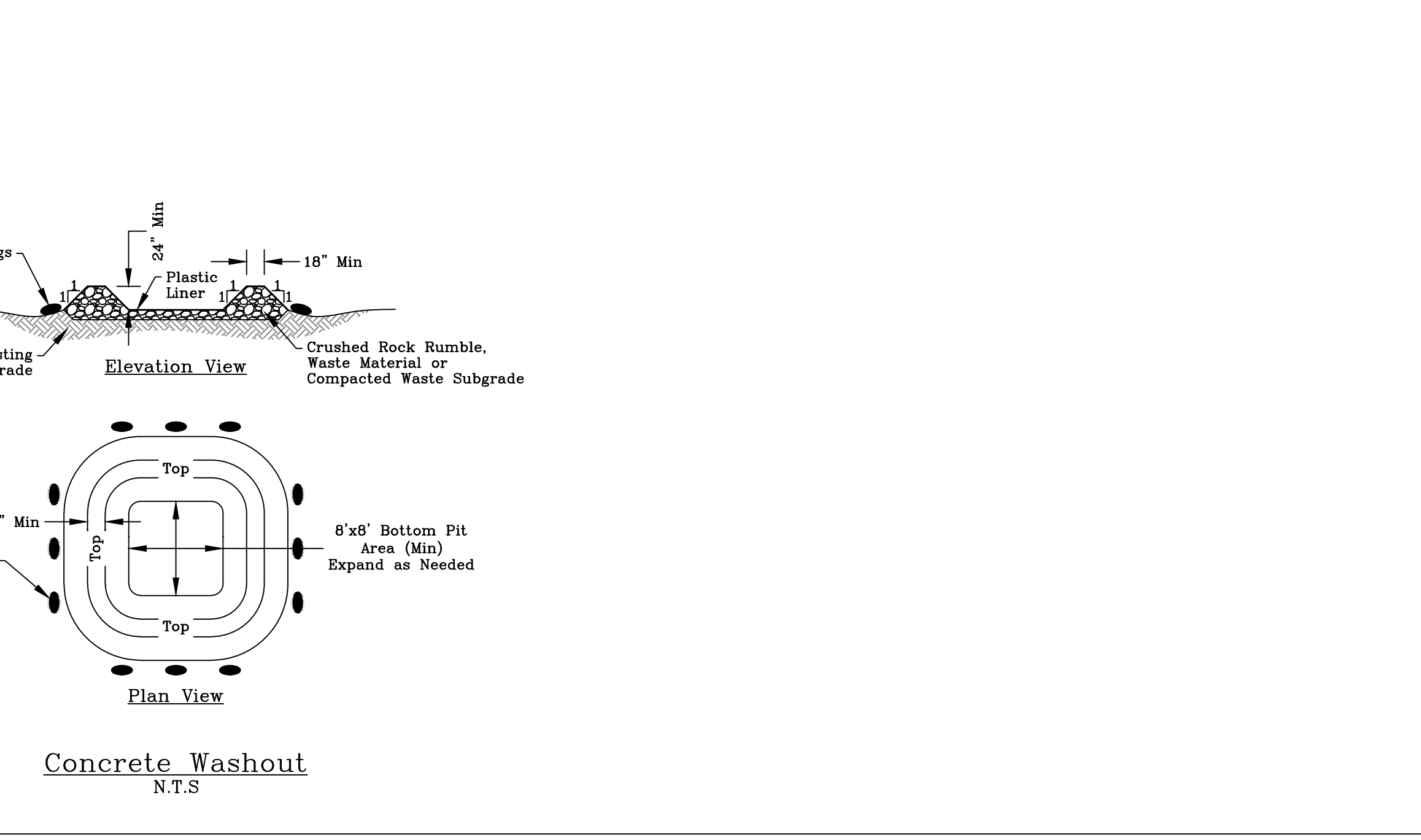

Site Plan

- ### General Notes:
- The topography shown is from field survey data.
 - All utilities shown are taken from the best available information based on construction utility documents obtained by J4 Engineering from City and Independent agencies and/or above ground field evidence. Shown positions may not represent as-built conditions.
 - The contractor shall be responsible for verifying the exact location of all existing underground utilities, whether shown on these plans or not. Notification of the utility companies 48 hours in advance of construction is required.
 - Contractor is responsible for field verifying existing and proposed grades prior to any construction and reporting any inconsistencies to the Owner.
 - Normal Domestic Wastewater is anticipated to be discharged from this development.
 - All construction shall be in accordance with the current BCS Standard Specifications, Details, and Design Guidelines for Water, Sewer, Streets, and Drainage, unless otherwise noted.
 - It is the intent of these plans to comply with all City of Bryan guidelines, details & specifications.
- Owner/Developer:
GRT Interests, LLC
P.O. Box 663
Bryan Tx, 77808
- Surveyor:
Paul Williams Land
Surveying Co.
1851 Briarcrest Dr.
Bryan Tx, 77802
RPLS #5743

Preliminary Plans Only Not for Construction

This document is released for the purpose of interim review under the authority of Glenm. Jones, P.E. 97800 on 5-Mar-25. It is not to be used for construction, bidding, or permitting purposes.

Released for Review

No.	Revision/Issue	Date

Firm Name and Address:

PO Box 5192 - Bryan, Texas - 77805
979-739-0567 www.J4Engineering.com
Firm # 9951

Project Name and Address:

1824 Cimino Dr.
Carrabba Industrial Park Ph 11
Block 1, Lot 9 - 1.44 AC
Bryan, Brazos County, Texas

Date: **March 2025** Sheet: **C1**

Scale: **As Noted**

J4E Project # 23-014 Phase 11 - Site Plans.dwg 3/5/25 J4 Engineering

Grading Notes:

- Fill material used to achieve grade in areas to receive pavement or within the street right-of-way shall be compacted to at least 98% of the maximum dry density as determined by the standard proctor test, (ASTM D698), at a moisture content from optimum moisture content to 4% above the optimum moisture content. Areas outside of the street right-of-way shall be compacted to 95% of the maximum dry density.
- ADA ramp slopes shall not exceed 1:12h.
- Structural backfill for utility or storm drain trenches is required whenever the trench is within 5' of pavement or sidewalk.
- The contractor shall follow the general intent of the grading plans. minor adjustments to the actual elevations shown on the grading plan may be required to match existing ground elevations and structures. The proposed contour lines shown are approximate only, the design grade spot elevations should be used for construction of the site work.
- The contractor shall salvage all topsoil and replace it on all disturbed areas. all parking lot islands and areas adjacent to parking and sidewalk areas shall receive 6" sandy loam topsoil prior to placement of grass sod or hydromulch.
- The contractor shall field verify and locate all existing utilities on site prior to demolition.
- The contractor shall install all erosion and sediment control devices, as shown, prior to commencing demolition work.
- Should any existing utilities not shown or shown incorrectly on this plan be found on site, the contractor shall contact the design engineer immediately to discuss any possible conflicts before proceeding with any work in that area.

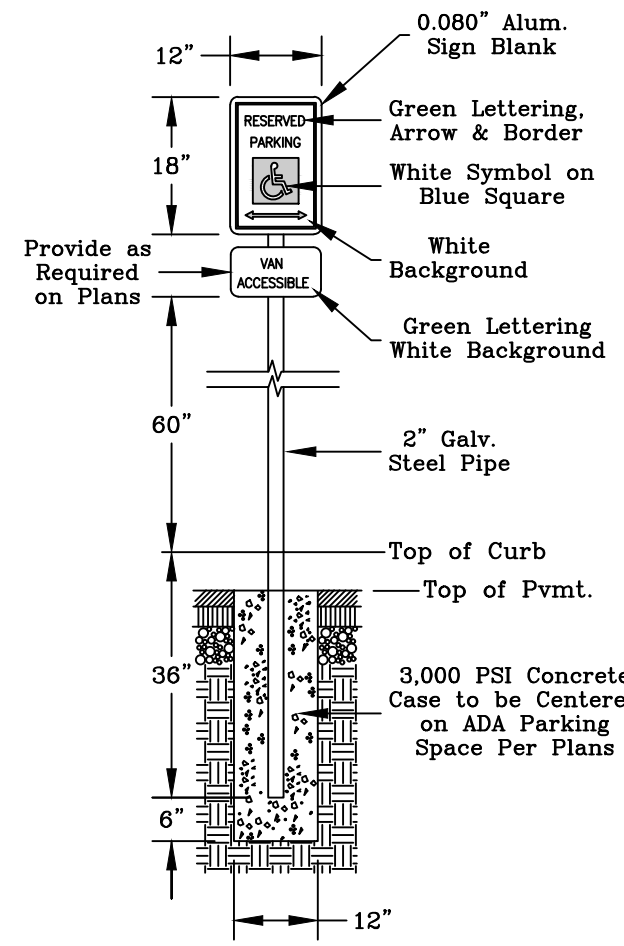

ADA Parking Sign
N.T.S

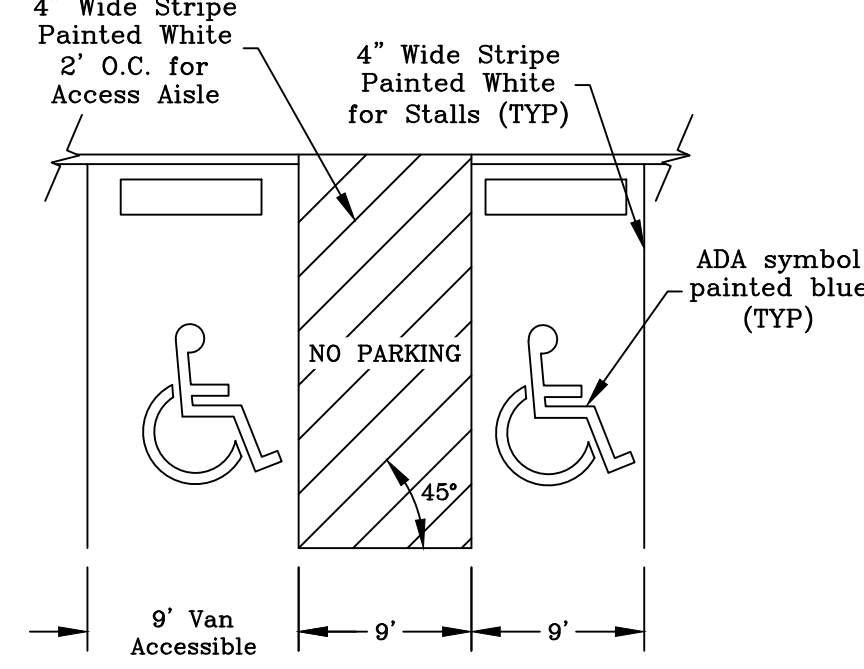

ADA Pavement Markings
N.T.S

Landscape Notes:

- All disturbed area to be seeded with Bermuda Grass except where Bermuda Grass Sod is called for on the plans.
- Replacement of dead landscaping shall occur within 90 days of notification. Replacement material must be of similar character as the dead landscaping. Failure to replace dead landscaping, as required by the zoning official or his or her designee, shall constitute a violation of this article subject to the general penalty provisions of City Code section 1-14.
- All trees shall be provided as container grown trees.
- All landscaping plant material shall be guaranteed for a period of one year from the date of installation by contractor. After one year, the owner will be responsible for maintenance of all landscaping.
- Plant material shown here is represented at its mature size. Plants to be installed will be significantly smaller than those shown and should not be expected to reach maturity for several years dependant on growing conditions.
- Contractor is to seed all disturbed areas left unpaved and guarantee coverage of vegetation until establishment of grass. Grass type shall be Bermuda grass or Rye/Bermuda mixture.
- Plant material will be watered by hose bibs located at building corners.
- Plantings for parking lot screening (Crepe Myrtles) shall be planted a maximum of 3 feet from the edge of parking lot pavement. No plantings shall be placed directly over existing water/sewer lines.
- To ensure the growth of trees in end islands, a minimum 24-inch soil depth and 250 cubic feet of appropriate planting medium is required per tree, with topsoil mounded to a center height.
- Outdoor storage yards are excluded from the disturbed area landscaping calculations per the PD Ordinance.

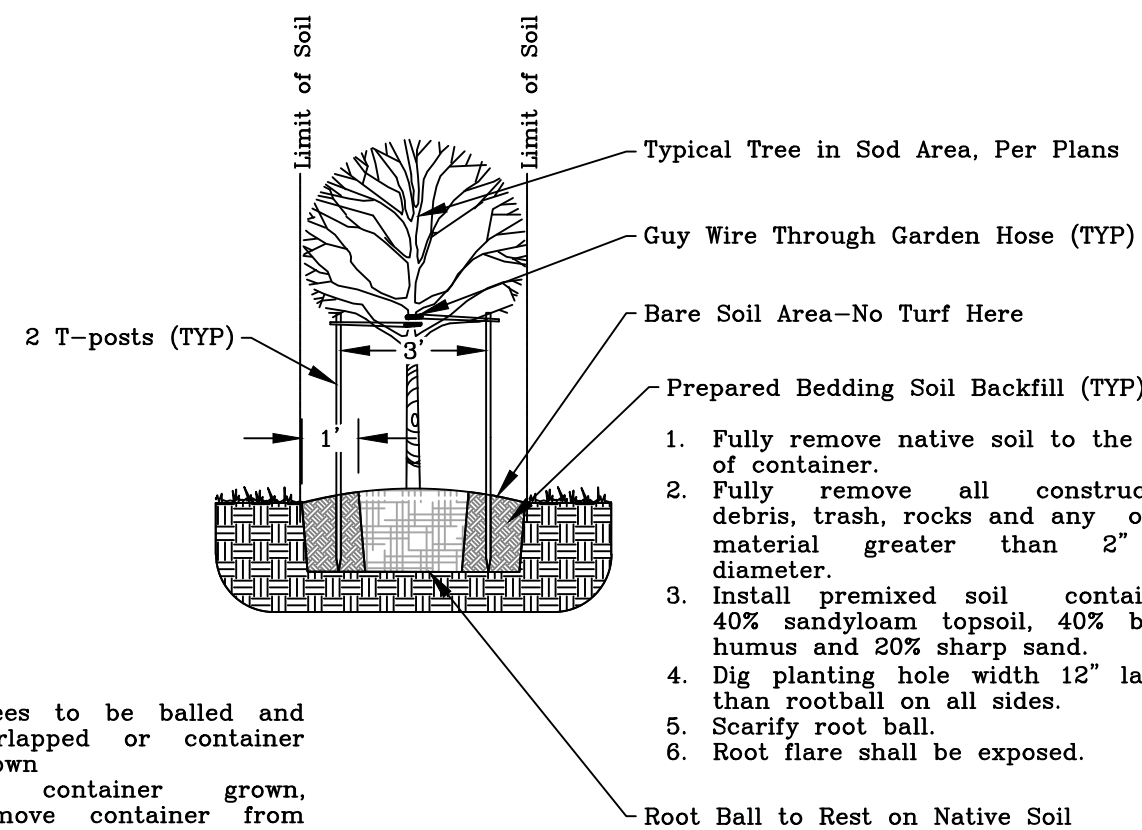

Tree Staking & Planting
N.T.S

- Notes:
- Trees to be balled and burlapped or container grown.
 - If container grown, remove container from tree before planting.
 - Top of root ball to be 3" higher than final grade.
 - Top of root ball to be exposed.

Solid Waste Notes:

- Before enclosure construction/modification begins contact Solid Waste, at (979)209-5900 for an on-site review.
- If any changes are made to the enclosure plan during the construction phase please contact Solid Waste to review modifications.
- Dumpster containment areas shall use 8" concrete, reinforced with #5 bars at 12" OCEW and the pad shall extend an additional 10' in front of the containment area.
- The dumpster containment area shall be surrounded on three sides with a screen constructed to a height of six feet.
- An all-weather access route (i.e. parking lots, loading docks, private roads, alleys, etc.) capable of supporting the container and the collection truck must be constructed and will be maintained and repaired at the business owner's expense.
- The pad, screening and doors will be constructed and maintained at the property owner's expense

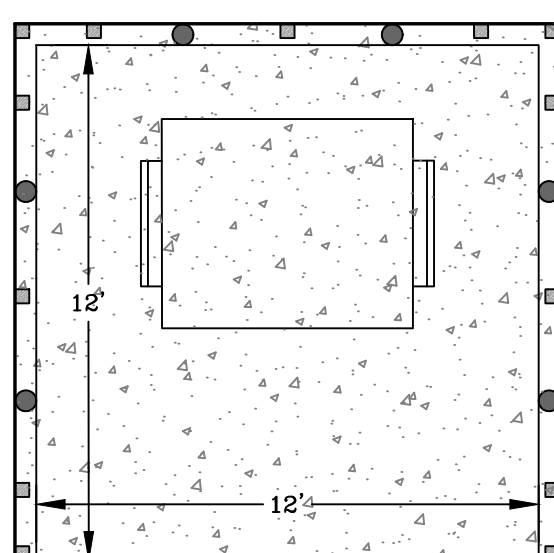

Dumpster Enclosure - Plan
N.T.S

Notes:

- All lumber shall be weather resistant cedar or pressure treated.
- Pickets are to be 1x6, dog-eared, fastened w/ 1 1/2" galv. screws, min 2 per connection.
- Rails are to be 2x4 fastened w/ 3" galv. screws, min. 3 per connection.
- Post are to be 4x4, placed 6' O.C., & set in 3,000 PSI concrete.
- Screening fence & post are to be placed outside dumpster pad.

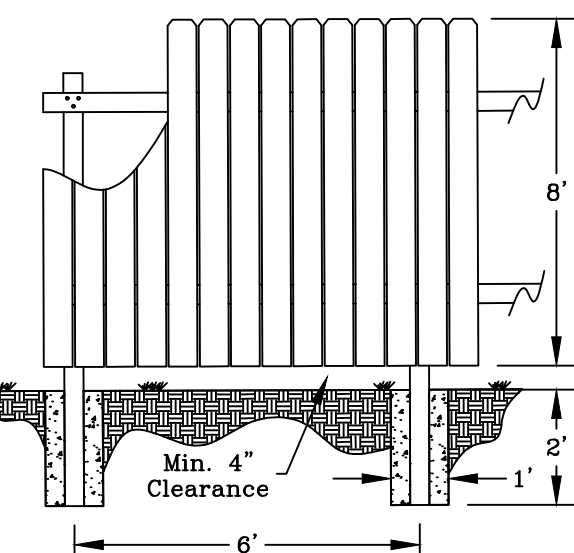

Dumpster Enclosure
N.T.S

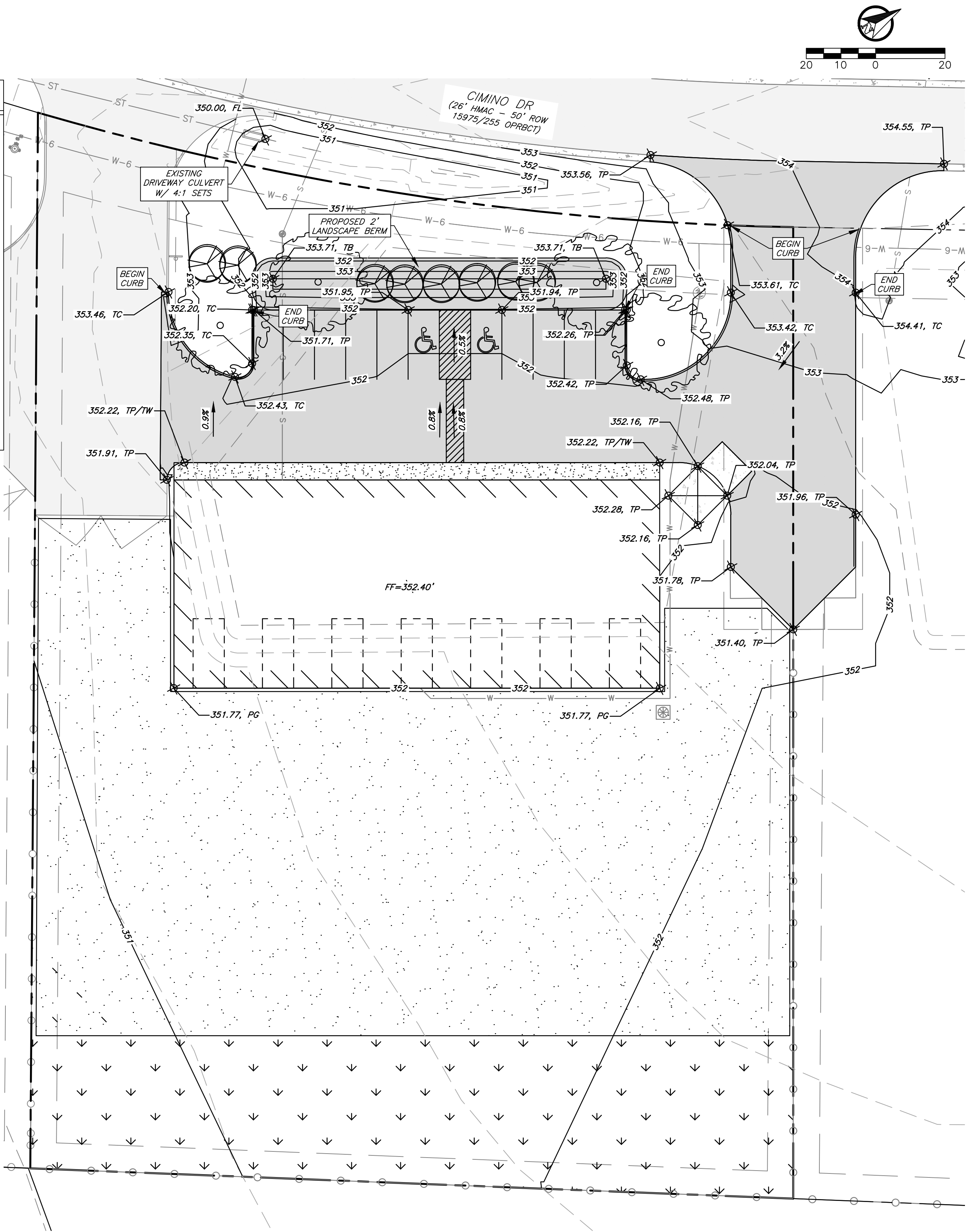
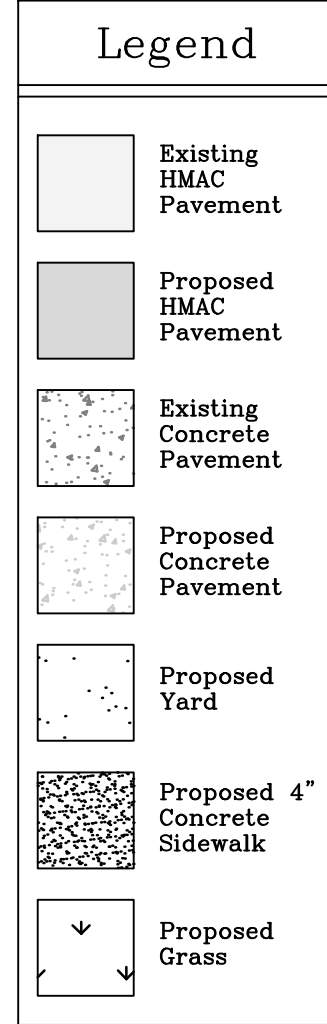

Grading & Landscape Plan

General Notes:

- The topography shown is from field survey data.
- All utilities shown are taken from the best available information based on construction utility documents obtained by J4 Engineering from City and Independent agencies and/or above ground field evidence. Shown positions may not represent as-built conditions.
- The contractor shall be responsible for verifying the exact location of all existing underground utilities, whether shown on these plans or not. Notification of the utility companies 48 hours in advance of construction is required.
- Contractor is responsible for field verifying existing and proposed grades prior to any construction and reporting any inconsistencies to the Owner.
- Normal Domestic Wastewater is anticipated to be discharged from this development.
- All construction shall be in accordance with the current BCS Standard Specifications, Details, and Design Guidelines for Water, Sewer, Streets, and Drainage, unless otherwise noted.
- It is the intent of these plans to comply with all City of Bryan guidelines, details & specifications.

**Preliminary Plans Only
Not for Construction**

This document is released for the purpose of interim review under the authority of Glenn Jones, P.E. 97600 on 5-Mar-25. It is not to be used for construction, bidding, or permitting purposes.

Released for Review

No.	Revision/Issue	Date

Firm Name and Address:

 PO Box 5192 - Bryan, Texas - 77805
 979-739-0567 www.J4Engineering.com
 Firm# 9951

Project Name and Address:
1824 Cimino Dr.
 Carrabba Industrial Park Ph 11
 Block 1, Lot 9 - 1.44 AC
 Bryan, Brazos County, Texas

Date: **March 2025** Sheet:
 Scale: **As Noted** **C2**

J4E Project # 23-014 Phase 11 - Site Plans.dwg 3/5/25 J4 Engineering